

ASSESSMENT OF SUPERSTRUCTURE EFFECT UPON THE SUBMARINE STABILITY IN SURFACE CONDITION IN HEAVY SEAS

Andrey V. Efimov, Valery O. Mrykin, Andrey I. Baranov
Central Design Bureau for Marine Engineering «Rubin» (Russia)

Abstract

The subject of consideration is the influence of the permeable superstructure on the submarine stability in storm conditions.

In the process of heaving sea water penetrates into superstructure during the diving stage. During the surfacing stage part of water does not have time to flow out through the flood ports and being the liquid cargo located on a high level reduces the stability of a submarine.

The method of the submarine stability estimation taking into account this factor is proposed. The results of the estimation of behavior of a submarine with big superstructure in storm conditions and the recommendations how to increase the safety of submerged navigation are provided.

1. INTRODUCTION

For a submarine one of the most important operation safety criteria is the transverse metacentric height in surface position. Its value is standardized and indicated in the design operational-tactical requirements and later on in the specification. As a rule the standardized values are the result of the generalization and analysis of many years of experience in operating of similar ships.

However the exceptions to this practice are possible which are stipulated by the special features of the submarine design. All types of submarines have superstructures.

This structure is water permeable: in the process of diving (surfacing) the sea water flows in (flows out) into the superstructure through the flood ports located in her lower

part and air comes in (comes out) through the ventilation holes in the superstructure deck

In storm conditions the submarine performs the heaving and superstructure dives and surfaces (partially or fully) in turn. As a result part of the water stays in the superstructure which leads to the temporary (on the surfacing stage) reduction of transverse stability due to the influence of the liquid cargo located on the high level. See figure 1.

2. METHOD OF ANALYSIS

While designing a submarine with big superstructure as a special feature, the task was given: to estimate the stability and behavior of a submarine heel wise taking into account the above-mentioned factor. For this purpose the method was proposed including the following:

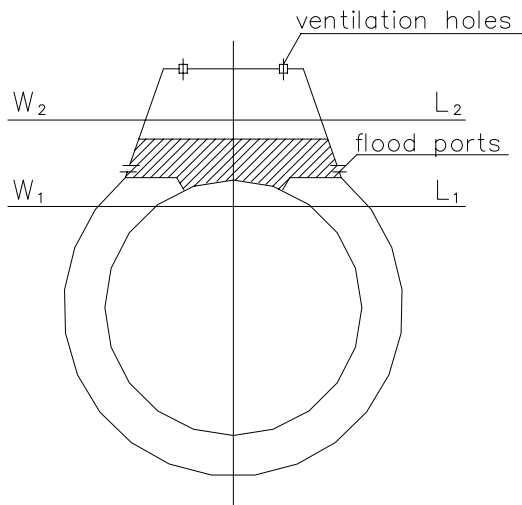

Figure 1. Submarine position during heaving: W_1L_1 - water line corresponding to the maximum surfacing level in the process of heaving; W_2L_2 - water line corresponding to the maximum diving level in the process of heaving. Water in the superstructure is section-lined.

- Mathematical modelling of submarine heaving taking into account the process of flooding-draining of the superstructure; as a result the following forces are defined: force by gravity, inertial force, buoyancy force and hydrodynamic resistance force.
- Calculation of the moments of the mentioned forces M_θ in transverse plane depending on the heel angle θ (transverse stability diagram) for certain positions of the submarine covering the range of draughts from the biggest diving level to the biggest surfacing level in the process of heaving;
- The analysis of the obtained set of diagrams $M_\theta = f(\theta)$ related to the safety of submarine navigation in storm conditions.

Thus the process is presented as a set of instantaneous positions of a submarine with forces in equilibrium in compliance with

Dalamber principle [1]. Each function $M_\theta = f(\theta)$, is similar to Reed diagram, but the dynamics of the process is taken into account. The calculation of the transverse stability diagrams can be performed by well known ship's statics methods; at the same time the assumption is accepted, that a line of inertia force action comes through the center of gravity of a submarine and the line of action of the force resisting vertical motion goes through the center of submerged part of a submarine.

In CDB ME "Rubin" the engineering technique for making the appropriate calculations was developed.

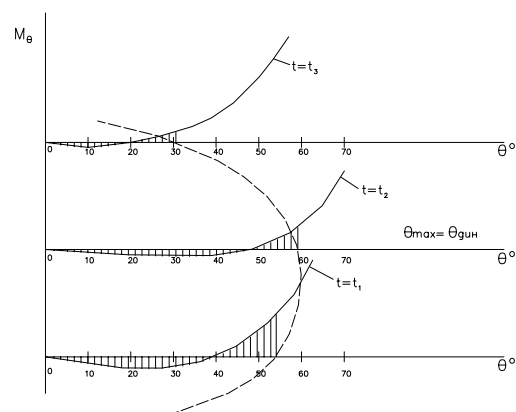

Figure 2. Transverse stability diagram in different moments of time.

On figure 2 the set of transverse stability diagrams was shown for example, calculated for above-mentioned submarine.

The diagrams correspond to the half-period of the heaving during submarine surfacing, the moment of time corresponds to the highest surfacing position.

It is evident from stability diagrams shown on figure 2 that in the process of submarine surfacing the steep reduction of stability takes place when the zone of negative values with rather long duration appears. The stability moment getting negative values turns from the point of acting on a submarine into heeling moment instead of restoring one causing the

heeling of a submarine. The role of heeling «releasing mechanism» can be played by external forces and also the oscillations of water in the superstructure.

The maximum angle of heel is equal to dynamic angle of heel on the transverse stability diagram for the position of the highest level of submarine surfacing. Dynamic angle of heel θ_{dyn} is defined by energy method, by means of making equal the areas between the axis of heel angles and positive and negative “branches” of transverse stability diagram. Such approach to the dynamic stability studies taking into account the influence of mobile cargo is not strict enough but it is used both in practical calculations and for standardization of ship’s stability [2]. As it was shown in work [3], the calculation of dynamic heel angles using static stability diagrams taking into account the three liquid surfaces leads to small errors with deviation on the safe side.

The behavior of the ship having such character of transverse stability diagram should be distinguished by krankiness as it is known from the practice of shipbuilding.

The results of operating submarines of this project match the results of theoretical estimation both with respect of behavior in storm conditions and with respect to heel angle values. Being in surface position during sea state 6-7, the submarine was periodically heaving to the side with heel angles 45-50°. In this case the delays in heaved position lasting for 3-4 sec. (one time for 12-13 sec.) and slow return to up right position confirm the previously made conclusion that the steep reduction of transverse stability is the main reason of the occurrence of big heel angles. It is evident that the factor of flooding of superstructure by water depends greatly on the height and period of waves; it reveals itself to a greatest extent during resonant heaving.

For the elimination or reduction of submarine krankiness the following can be done:

- increasing of transverse metacentric height up to the values sufficient for the compensation of negative water influence in the superstructure;
- optimization of flood port area in the superstructure.

As applied to the submarine – the object of our research on the basis of transverse stability diagrams the functions $\theta_{max} = f(c_h)$ are constructed, where c_h - effective area of the flood ports in the superstructure, for several values of transverse metacentric height values. It should be mentioned that the reduction of flood ports area leads to the delay of water discharge from the superstructure during surfacing of the submarine from the depth to the surface and big heel during this manoeuvre. The attention to this fact was attracted in work [4].

On figure 3 - h_0 - initial value of transverse metacentric height. On figure 3 two of such graphs are given as example. The maximum values on the graphs correspond to the non-optimum value of flood ports area in the superstructure.

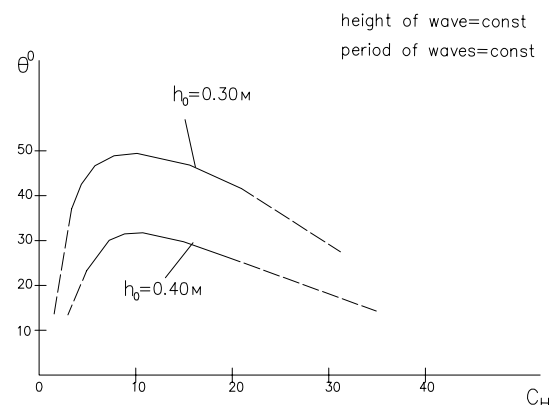

Figure 3. Dependence of heel angle from flood ports effective area and initial stability.



3. CONCLUSIONS

Summarizing the above-mentioned the following conclusions can be made:

1. During heaving sea water flows into the superstructure of a submarine, its flowing outside is delayed and as a result the transverse stability is reduced.

For the submarines with big superstructures this factor can result in creation of krankiness and big heel during cruising in stormy conditions.

2. The proposed method enables to evaluate the behavior of a submarine and effectiveness of design solutions aimed at the reduction of heel angles of the submarine of concrete project while cruising in storm conditions.

3. While making calculations of rolling in order to avoid the principle mistakes in the evaluation of the submarine behavior, it is advisable to assume as initial data the transverse stability characteristics taking into account the influence of water in the superstructure.

Finally it should be mentioned that the conclusions have been received as the result of

the research related to a submarine of concrete project and though most probably they are of general character, they are subject to further check and specification.

4. REFERENCES

- [1]. P. Appel. Mechanics. State Publishing House of Foreign Literature. Moscow, vol. 1. (translation from French the book «Tractate on Theoretical Mechanics»), 1947.
- [2]. Voevodin N.F. Changing of stability of vessels. Leningrad, «Sudostrojenie», 1973.
- [3]. Maltsev N.Y. The dynamics of the ship with liquid cargo. – Variety methods in the problems related to the liquid oscillations and body with liquid. Computing center USSR AS, 1962.
- [4]. Efimov A. V., Baranov A. I., Mrykin V. O. Stability of Underwater Vehicle in the Process of Crossing the Sea Surface While Surfacing. 10-th Congress of International Maritime Association of the Mediterranean, 2002.